



Performance with style

900

When you choose the 900 sliding door you'll experience the ultimate in high performance weathering, low air infiltration, commercial strength and patented AGS advanced tracking system. Tested to AS2047 and utilising Capral ecometal™ the 900 sliding door has been engineered to suit Australia's harsh conditions making it the highest performing door on the market.

Developed for high rise apartments and prestige residential projects, the 900 sliding door offers multiple configurations and total functionality with a stackable head, sill, and jamb allowing unlimited sashes to be used.

It can be coupled to the Capral 400 Narrowline framing system allowing you to experience a perfect site line with a modern look and sleek lines through its innovative styling.

The 900 sliding door is a superior choice for living areas that seek to achieve maximum use of available space together with outstanding panoramic views.

When installed, it gives the illusion of a bigger room, with more space, natural light and the glazing options to keep your room cool in summer and warm in winter.

CAPRAL

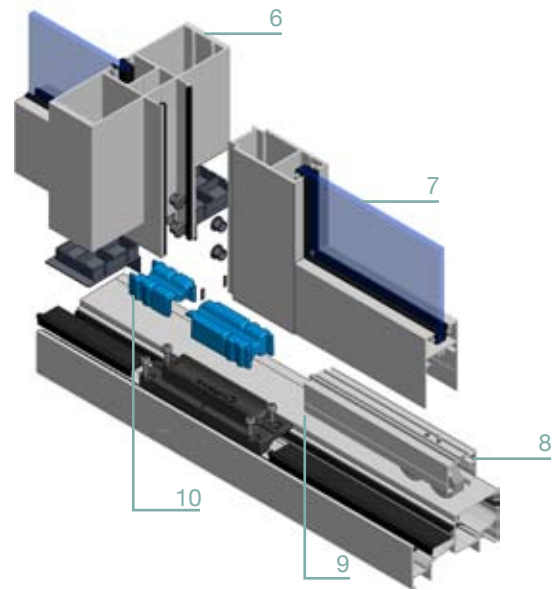
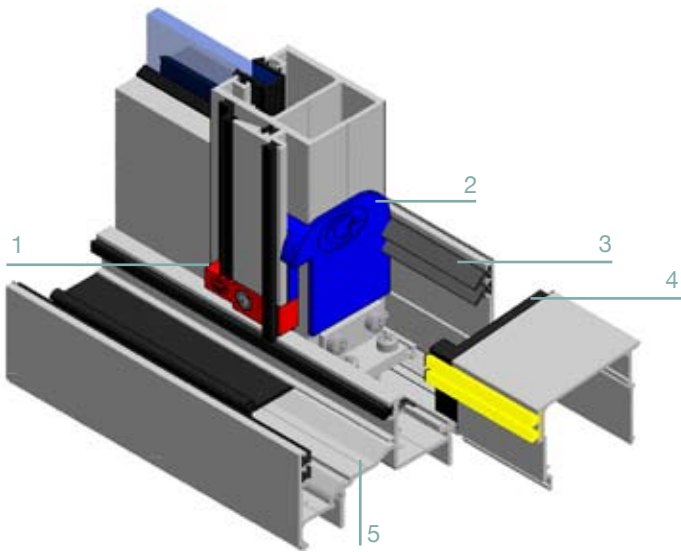

1. Anti-lift block
2. High-pressure threshold caps
3. Co-extruded santoprene fin seals
4. High-pressure threshold caps
5. Sill-standard and high performance options

6. Range of stiles & interlocks to meet performance requirements
7. Single or double glazed
8. Various hardware options
9. Super clean lines minimize dust and dirt
10. Patented interlocking components for increased performance

Superior features and high class design



- Internal or external security screen option
- Compatible with 400 Narrowline framing system
- Supports glass thickness from 4mm single glazed through to 26mm double glazed
- Double-bogey ball bearing rollers support up to 240kg
- Various lock options including surface mounted locks and mortice-style deadlocks
- Designed for superior energy performance

Product Specifications

- Serviceability Wind Pressure: Up to 6000 Pa*
- Ultimate Wind Pressure: Up to 7700 Pa*
- Water Penetration Resistance: Up to 700 Pa*
- Maximum Panel Height: 3000mm
- Maximum Panel Width: 1500mm
- Maximum Panel Weight: 240kg Heavy Duty only

* Dependant on size, configuration, sill & stile type
(Refer to your account manager or AGS technical manual)

* Components are coloured for indication only

Contact your local AGS fabricator for further details.

