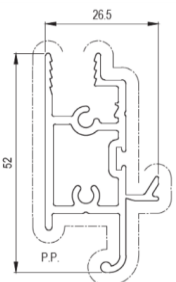
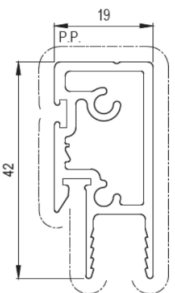

<b>PRODUCT BULLETIN No. 236</b>
<b>AGS 481 &amp; Urban 581 Double Hung Interlocks</b>
<b>Residential</b>

In order to continue to improve Capral's offer, we are now pleased to announce the below upgrades to the AGS 481 & Urban 581 Double Hung.

Capral has added a new set of Interlocks that provides greater strength, along with a more pleasing aesthetic architectural look.

EP16246 – Heavy Duty Bottom Interlock	EP16247 – Heavy Duty Top Interlock
	

The addition of the DH Stiffener ED8610, provides extra strength on top of the increase already produced from this combination.

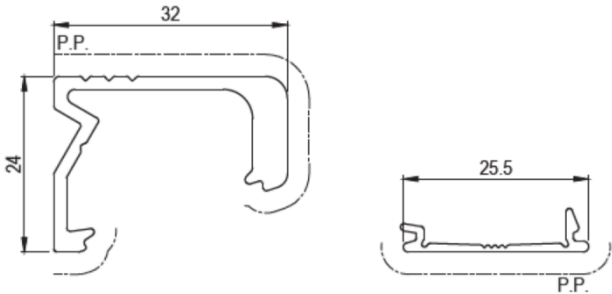
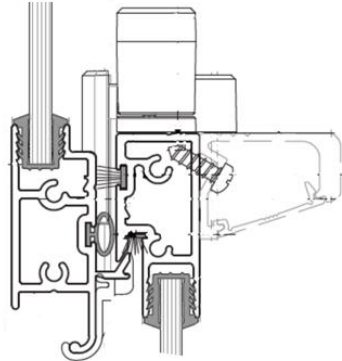
ED8610 – Double Hung Interlock Stiffener ED8611 – Stiffener Infill	
	

These new extrusions are now available and stocked in various locations.

### **Technical Notes**

The Technical Manual is currently available to download from the Capral website. The various software systems have been updated to reflect the new offer



**Matthew Finnie**

National Manager Window & Door Systems